

ELEMENT RANGE BATTERY

E-BATT

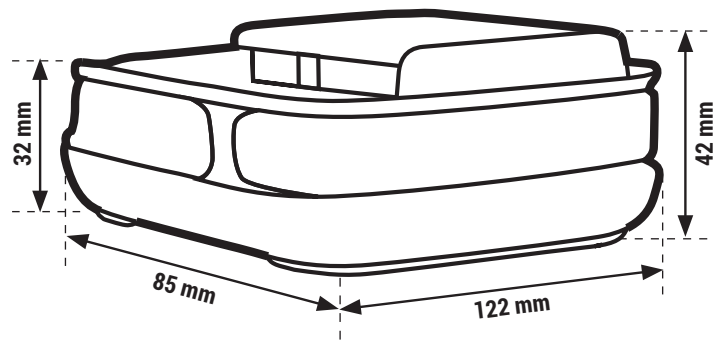

SPECIFICATIONS

Rated Voltage: 18 V Li-ion - 2.0 Ah **Capacity:** 2.0 Ah
Battery Type: Li-ion **Weight:** 0,36 kgs
Cells: 5 cells **Warranty:** 1 year

Battery autonomy with 1 charge:

RIVETS	MATERIAL	APPROX. PIECES/CHARGE
Ø4.0	Aluminium	1 280
Ø4.8	Aluminium	980
	Steel	720

COMPLEMENTARY PRODUCTS

Charger :
 18V - battery charging time 2.0 Ah = 100 % in 30 minutes

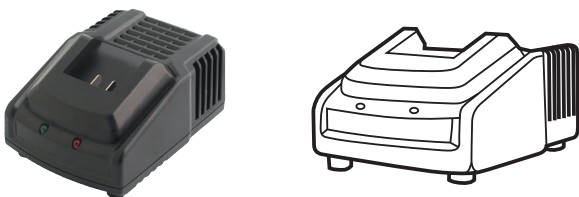

Input Voltage: 100-240VAC/50-60Hz
Output Voltage: 18VDC
Output Current: 2,5A max.
Weight: 0,37 kgs

OPERATING INSTRUCTIONS

• BATTERY LEVEL INDICATOR:

4 lights on the battery panel allows you to check the remaining power. Press and hold the blue button to check the battery level :

- 4 lights on : 100% remaining
- 3 lights on : 75% remaining
- 2 lights on : 50% remaining
- 1 light on : 25% remaining

The information on the battery panel can vary (+/- 5%) due to environmental conditions.

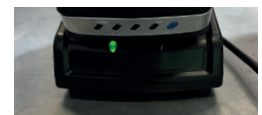

Green light on the charger: the battery is fully charged

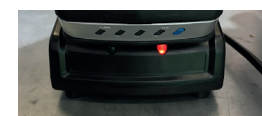

Red light on the charger: the battery has to be charged

• REMOVE THE BATTERY:

Battery is locked to the riveting tool with a spring. To remove the battery, press the 2 unlock buttons and slide the battery.

REFERENCES

REFERENCE	E-BATT
-----------	--------

MAINTENANCE / TROUBLESHOOTING / SAFETY INFORMATION

See user manual.