

# HCD - STEEL HEXAGON FLANGE INSERT

Insert. Hexagon Body. Steel zinc.

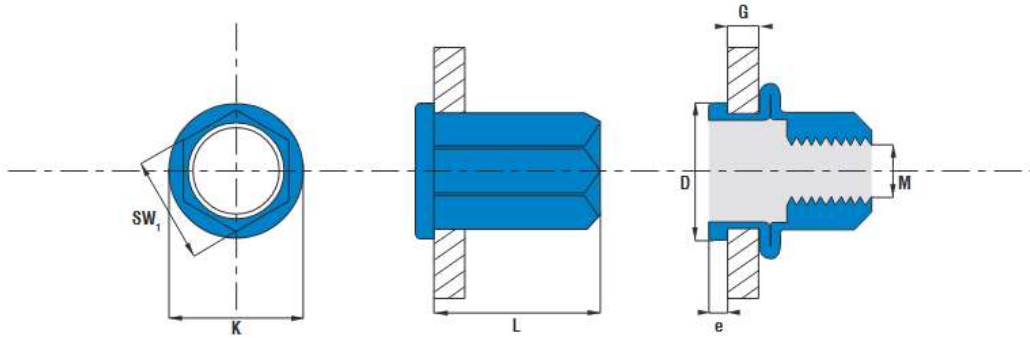

PART NO/REF	M	L	K	e	D	SW1	G
	Ø (mm)	(mm)	(mm)	(mm)	(mm)	(mm)	min-max (mm)
HCD0430	M4	12.5	9.3	1.0	9.3	6.1	0.5-3.0
HCD0530	M5	14.5	10.3	1.0	10.3	7.1	0.5-3.0
HCD0630	M6	17.0	12.3	1.5	12.3	9.1	0.5-3.0
HCD0660	M6	19.0	12.3	1.5	12.3	9.1	3.0-6.0
HCD0830	M8	19.0	14.3	1.5	14.3	11.1	0.5-3.0
HCD0860	M8	20.5	14.3	1.5	14.3	11.1	3.0-6.0
HCD1040	M10	24.0	16.3	2.0	16.3	13.1	1.0-4.0
HCD1240	M12	27.0	20.3	2.0	20.3	16.1	1.0-4.0

	RECOMMENDED MAX TORQUE	PULL-OUT	SHEAR
M (mm)	(Nm)	(N)	(N)
M4	7.9	6 400	2 300
M5	12.2	11 000	3 600
M6	20.5	18 000	4 300
M8	26.7	28 000	5 000
M10	40.0	30 000	6 000
M12	49.0	35 000	7 000